

Development and performance of a 10 kW PEMFC stack

J. Scholta^{a,*}, N. Berg^b, P. Wilde^b, L. Jörissen^a, J. Garcke^a

^a Zentrum für Sonnenenergie- und Wasserstoff-Forschung, GB 3: Elektrochemische Energiespeicherung und -wandlung, Helmholtzstr. 8, D-89081 Ulm, Germany

^b SGL Technologies GmbH, Werner-von-Siemens-Str. 18, D-86405 Meitingen, Germany

Abstract

PEM fuel cells are viewed as one of the most environmentally friendly propulsion systems for automotive travel in the future. However, the PEM fuel cell is still too expensive for wide-spread commercialization. Besides the membrane electrode assembly, manufacturing of bipolar plates by milling from graphite or graphite composites is a very expensive process. In order to achieve cost reduction and at the same time meeting several technical requirements for mass production, a stack concept using graphite composite bipolar plates was developed. The tests reported in this paper show that the design goal of 10 kW could be significantly exceeded.

© 2003 Elsevier B.V. All rights reserved.

Keywords: Fuel cell; PEMFC; Stack

1. Introduction

PEM fuel cell stacks are currently available in a prototype stage and often not readily available on the market [1]. One of the main issues is the simultaneous improvement of stack performance and cost reduction [2]. The objective of this work was the development of a comparatively inexpensive polymer electrolyte membrane fuel cell (PEMFC) stack technology allowing operation at a power of 10 kW at non-pressurized conditions. In the following sections, data on the sub-scale and full-size stack level will be presented.

2. Experimental procedures

2.1. Basic stack design

The stack was built from graphite composite bipolar plates having “cast in place” (CIP)-sealing already integrated in the plate. Serpentine type flow fields were used for gas distribution on anode and cathode side. GORE PRIMEA 5510 MEAs were used having a platinum loading of 0.3 mg/cm² at the anode and 0.4 mg/cm² at the cathode side. The MEA edges were reinforced by a rigid polymer film. Two dif-

ferent types of gas diffusion layers having a thickness of approximately 400 μm were tested. The first type was made from 26% PTFE impregnated Toray TGP 120 graphite paper. The second type was prepared by SGL Technologies from a non-woven basic structure, PTFE impregnation and a microlayer facing the catalyst coated membrane. The active area was 500 cm² which could be optimized to a final active area of 560 cm² by modifications of MEA sealing.

In the development phase reported here, the bipolar plates used were still machined. However, the basic design was adapted to manufacturing by volume manufacturing technologies such as compression or injection molding. For sealing, a viscous liquid elastomer was deposited into a V-shaped groove by a robot dispenser followed by thermal curing. Similarly, end plates were designed allowing manufacturing by either machining or casting. Media connection was made by O-ring sealed polymer flanges having an inner diameter of 40 mm. All media connectors were led to a single side. The current collectors in the final stack were made from gold plated copper.

The stacks were designed to achieve a power density of 250 mW/cm² at an averaged single cell voltage of 600 mV. Based on this assumption, a 10 kW-stack would require approximately 70 cells.

During the development process, three stacks were built. Their data are summarized in Table 1.

During the development process, further material and construction alterations were done as a result of the extensive stack testing.

* Corresponding author. Tel.: +49-731-9530-206;

fax: +49-731-9530-666.

E-mail address: joachim.scholta@zsw-bw.de (J. Scholta).

URLs: <http://www.zsw-bw.de>, <http://www.sgcarbon.com>.

Nomenclature

dp	dew point
p_{in}	inlet pressure
X_{an}	anode gas utilization
X_{ca}	cathode gas utilization

Table 1
Data of assembled stacks

Stack no.	No. of cells	GDL	Active area (cm ²)
I	3	Toray paper TGP 120	500
II	14	Toray paper TGP 120	500
III	72	SIGRACET® SGL-10BB	560

2.2. Test bench

The stack performance was determined in a test bench developed at ZSW in cooperation with hydrogen systems. Fig. 1 shows the test bench layout.

The test bench allows measurement and recording of all relevant data (stack and single cell voltages, current, temperatures and pressures). Moreover, high frequency resistance

(HFR) data at a frequency of 1 kHz can be recorded online. Gas humidification is achieved by passing the premixed reactant gases through a heated and isolated bubbler. A test bench similar to the system here is described in more detail in [3].

2.3. Test procedures

The stacks were tested under hydrogen-air as well as under simulated reformat-air conditions. However, since no Pt/Ru catalysts were used, CO was not added to the simulated reformat. Normal operating conditions were as follows: $T_{stack} = 65\text{ }^{\circ}\text{C}$, ambient outlet pressure, inlet dew point (both sides) from $30\text{ }^{\circ}\text{C}$ to $40\text{ }^{\circ}\text{C}$. Gas utilization 70%, air utilization 25%.

In the tests, the operating temperature, gas composition and gas utilization were varied.

3. Results and discussion

3.1. Test results

Fig. 2a and b shows the three-cell stack which was built in 2000. Fig. 3 shows the 14-cell sub-stack produced in 2001.

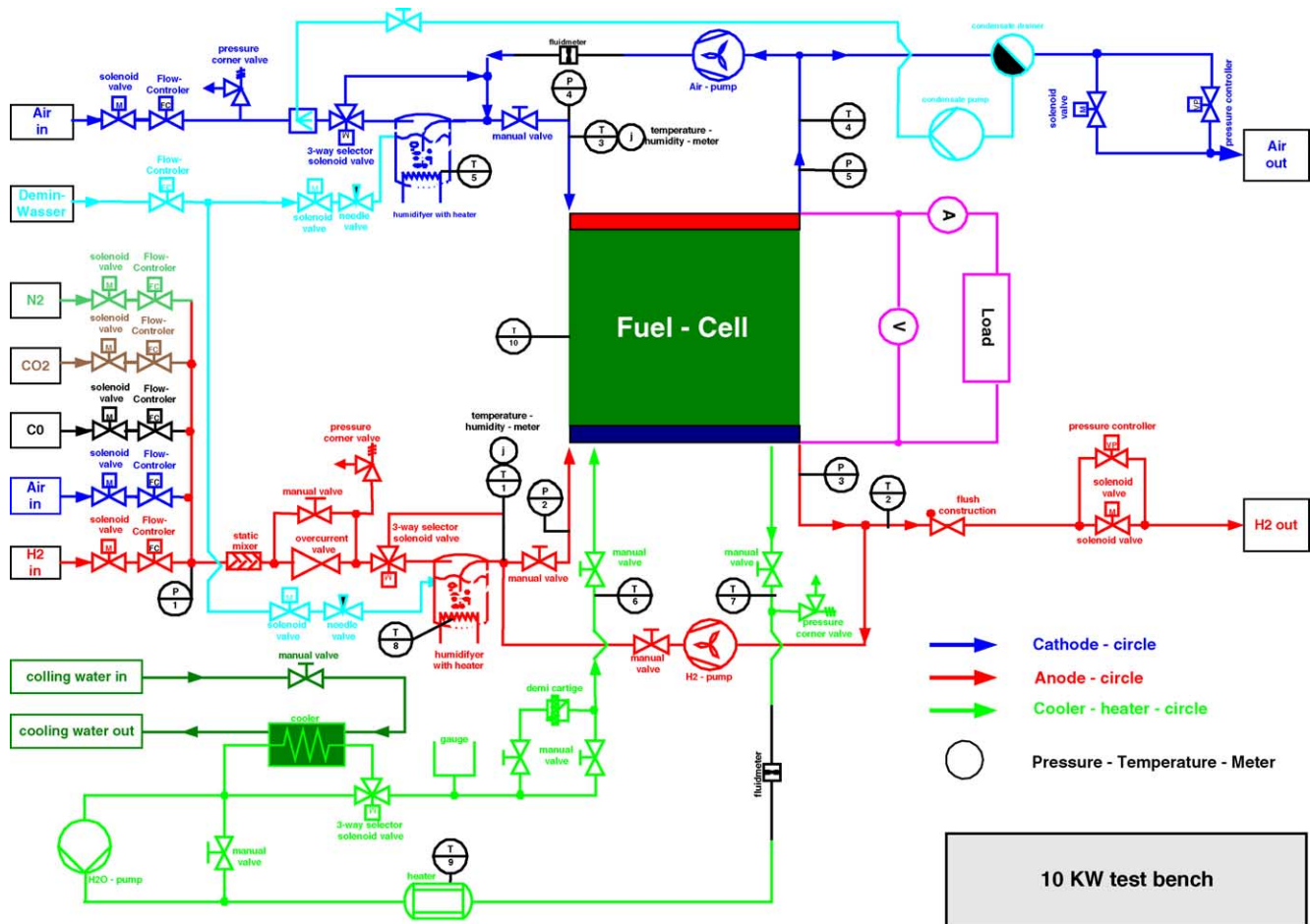

Fig. 1. Layout of 10kW test bench.

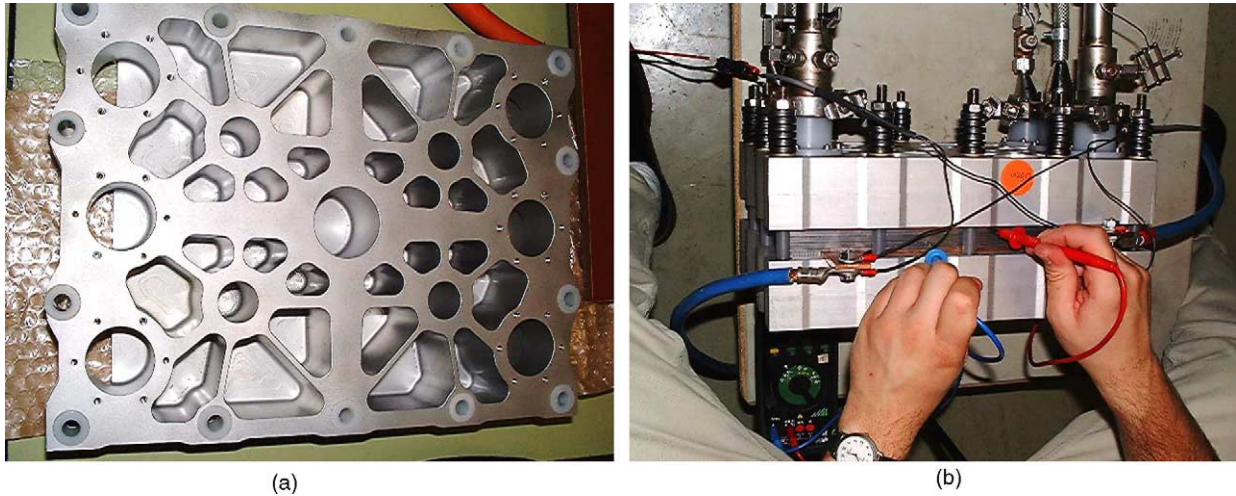

Fig. 2. Three-cell stack I (a) end plate (b) stack mounted in test bench.

The full size stack was assembled in late 2001 and is (as well as the 14-cell stack) currently undergoing endurance tests (Fig. 4).

3.2. Current–voltage-characteristics, performance

The first generation having three cells was intended to serve as a technology demonstrator. In spite of being designed for hydrogen operation, the stack was also tested using hydrogen CO₂ mixtures. The results are shown in Fig. 5. It is evident that the stack performance decreases to about 180 mW/cm² for a CO₂ content approximating a typical steam reformat. Nevertheless, if a moderate gas utilization is acceptable, also gas compositions typical for autothermal reforming processes can be used.

Fig. 6. shows the current–voltage-characteristics of stack I before and after an 800 h endurance-test. The design power density of 250 mW/cm² could be achieved at an averaged single cell voltage of 600 mV. Comparatively high interface impedance was observed at the current collector plates. After

800 h of operation, the power density at 0.6 V degraded to 220 mW/cm². The reasons will be discussed later.

The second generation stack having 14 cells showed a total power of 1.6 kW (600 mV single cell voltage) and a maximum power of 2.25 kW (at 520 mV). Characteristic

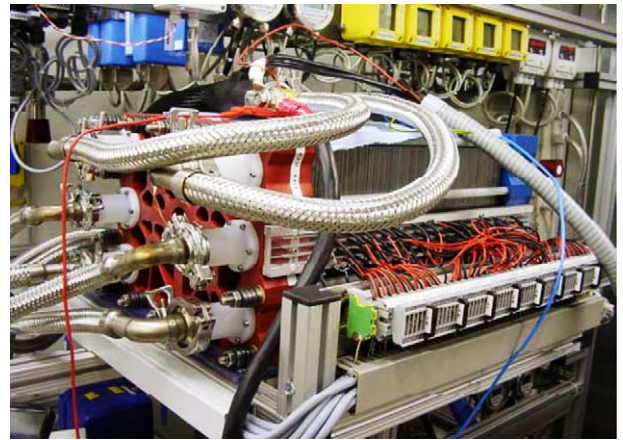

Fig. 4. Seventy-two-cell stack III in 10 kW test bench.



Fig. 3. Fourteen-cell stack II.

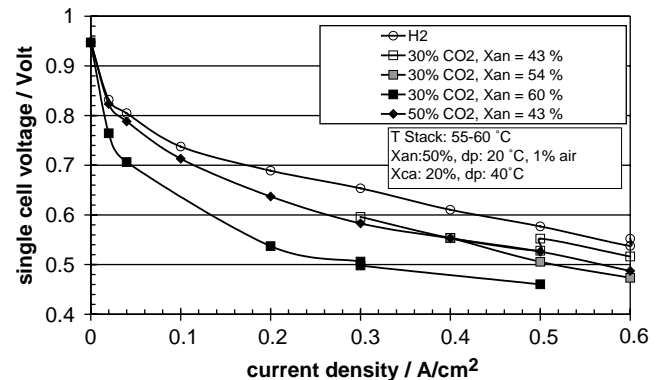

Fig. 5. Current–voltage-characteristics of stack I.

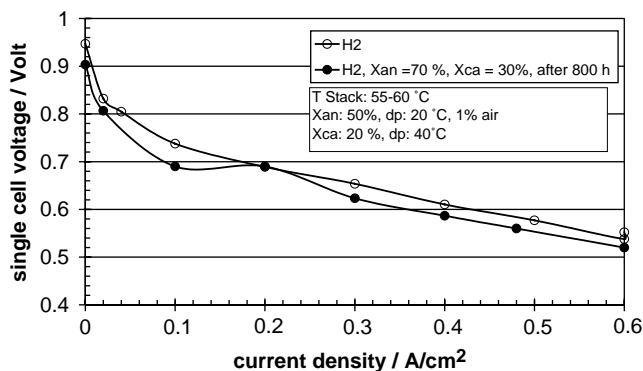

Fig. 6. Time dependence of current-voltage-curves (stack I).

curves for an operating temperature of 65 °C are shown in Fig. 7.

However, only a power density (stack II) of 210 mW/cm² (at 600 mV) could be achieved under these conditions.

The final prototype (stack III) was built using optimized gas diffusion layers from SGL Technologies as well as optimized current collectors. Fig. 8 shows current density curves for different operation conditions. If appropriate humidification conditions are chosen, the current voltage curve shows only low sensitivity to temperature changes between 55 and 65 °C. Only at current densities of more than 0.45 A/cm² a significant increase of voltage with temperature could be observed. Compared with stacks I and II, a single cell voltage increase of approximately 100 mV could be achieved at a current density of 400 mA/cm². The power density target of 250 mW/cm² was achieved at an averaged cell voltage of 700 mV.

The stack could be operated at 14 kW dc output power having an averaged cell voltage of 600 mV and above. Based on this performance, the specific power amounts to 200 W/kg and a power density of 285 W/l is achieved at ambient outlet pressure.

3.3. Pressure drop

All stacks show a linear flow pressure characteristic. A value of 76.4 mbar/(NI(H₂) min per cell) was measured at the anode side, the corresponding data for the cathode is 20.4 mbar/(NI(air) min per cell). The pressure drop along the cathode channel did not exceed 550 mbar.

3.4. Gas utilization

Fig. 9 shows the utilization-voltage curve of stacks II and III. It is evident that mass transport effects become visible at an anode gas utilization above 80% (Stoich 1.25). No significant differences were observed by the change from teflonized Toray paper to the SIGRACET[®]-material as gas diffusion layers. When comparing cathode gas utilization, one observes a wider range of acceptable performance when SIGRACET[®] gas diffusion material is used. When using teflonized Toray paper mass transport effects become evident already at a cathode gas utilization above 25% (Stoich 4), the stack using SIGRACET[®] gas diffusion materials could well be operated up to a cathode gas utilization of 50% (Stoich 2).

3.5. Uniformity of cell voltages

Fig. 10 shows the voltage distribution of single cell voltage for stack II at a current density of 600 mA/cm². The averaged cell voltage amounts to 569 mV at a standard deviation of 35 mV. The small increasing trend in cell voltage with cell number can be attributed to the higher internal cell resistance of the first cells which could possibly be attributed to inhomogeneous cell humidification within the stack. The full size stack III shows a comparable uniformity of cell voltages. This behavior demonstrates that all cells operate under a sufficient similarity of temperature and gas supply, indicating that the sizing of the media manifold channels is appropriate.

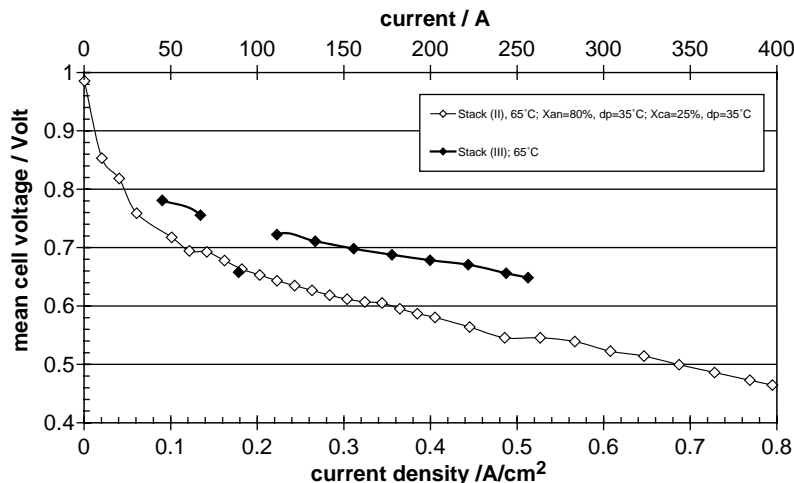

Fig. 7. Current-voltage-characteristic of stacks (II and III).

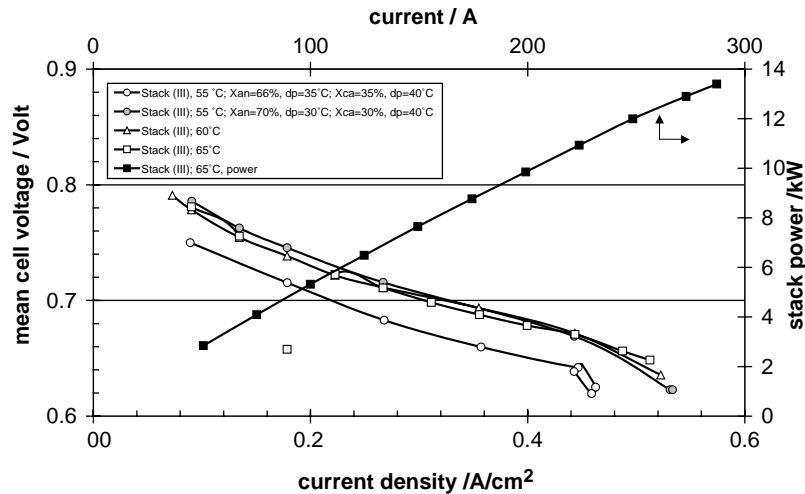

Fig. 8. Current–voltage and current–power-characteristic of stack III.

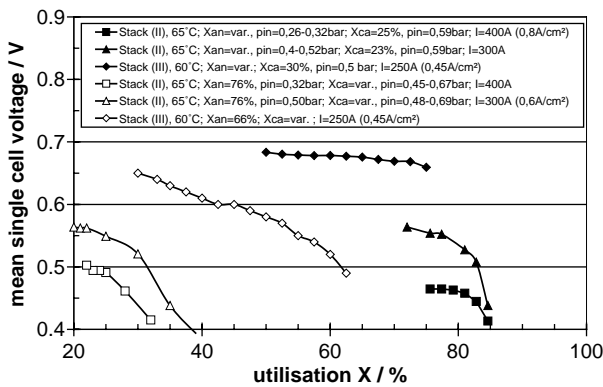

Fig. 9. Utilization–voltage-characteristics of stacks II and III: filled marks (anode), empty marks (cathode).

3.6. Endurance testing

Stacks I and III were tested for an extended time. The long term behavior of Stack I is compared with a sub-area stack using the same material combination as Stack III having an active area of 130 cm². Furthermore, the anode of the sub-area stack was operated in dead ended mode. The sub-area stack was operated at a current density of 300 mA/cm² whereas the large area stack (stack I) was operated at 600 mA/cm². The detailed operating parameters are shown in Table 2.

The test results are shown in Fig. 11. Stack I was operated more than 800 h. It is evident that stack I shows

severe performance fluctuations over time. However, even prolonged operation at a single cell voltage of approximately 350 mV did not damage the stack irreversibly. The rather strong fluctuations observed in stack I are most probably caused by insufficient water removal from the catalyst GDL interface. From a linear extrapolation of the performance data, a decay rate of 60 μ V/h per cell could be calculated.

The sub-scale stack shows a rather continuous long term behavior thus indicating improved water management by the SIGRACET[®] SGL-10BB gas diffusion layer. A linear decay rate of approximately 20 μ V/h per cell could be calculated. Nevertheless, even a semilogarithmic approximation of the decay rate could be justified as also shown in Fig. 11. Stack III shows a similar initial performance as the sub-area stack. Its long term behavior is still under investigation and results will be reported elsewhere.

Nevertheless, the difference in voltage decay rate between the sub-area and the full size stack is significant. In the following an explanation on a more or less hypothetical basis is attempted.

Besides differences in materials used for stack manufacturing, the most significant differences in the stack operating parameters are pressure drop as well as operating temperature. The sub-scale stack was operated at 55 °C, an anode inlet pressure of approx. 1.3 bar. The cathode pressure was close to atmospheric at inlet and outlet. Furthermore, a high air recirculation rate was used in the sub-scale stack. Dry input gases were used on both sides.

Table 2
Long-term operation conditions

	No. of cells	GDL	Active area (cm ²)	T_{stack} (°C)	H ₂ /air utilization (%)	H ₂ /air dew point (%)
Stack no. I	3	Toray TGP 120	500	65–70	85/30	35/35
Sub-area	50	SIGRACET [®] SGL-10BB	130	55	≈100/≈20	Dry/≈10 (40 ^a)

^a Dew point in recycle loop.

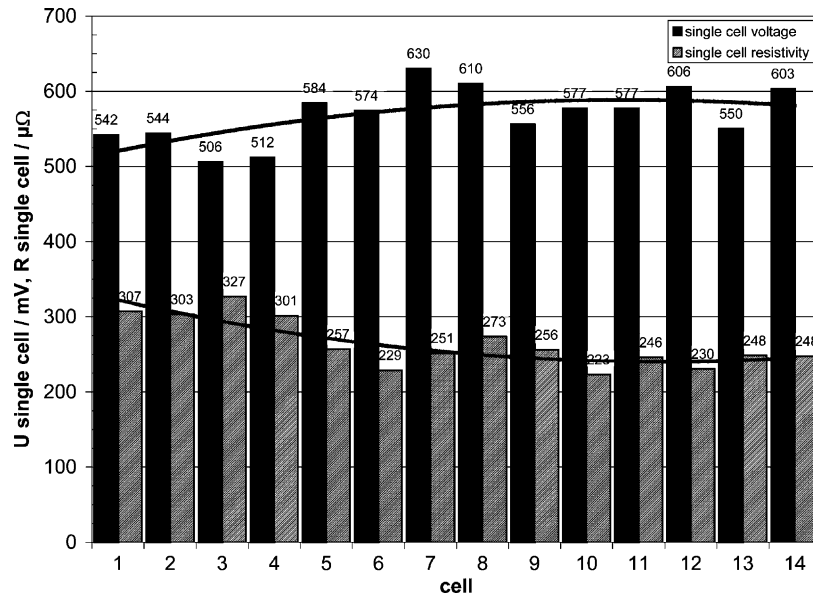

Fig. 10. Single cell voltages and resistances for stack II at a current density of 0.6 A/cm².

In the case of the full size stack, the operating temperature was set from 65 to 70 °C. Furthermore, a significant pressure drop is observed at the anode and the cathode side. Both sides were operated in flow through mode. Humidified gases were used at the anode and the cathode. It appears that the performance of stack I shows problems related to water management. It is well known that perfluorinated electrolyte membranes are losing water to the environment at temperatures around 70 °C even at 100% relative humidity. This could cause local areas on the large area MEA having steep gradients in water content thus leading to a more prominent

degradation. Furthermore, stack I was operated with twice the current density compared to the sub-scale stack which could also result in localized inhomogeneity in mass transport and temperature distribution possibly enhancing degradation phenomena.

The comparison of degradation rates between stack III and the sub-scale stack is subject to further investigation.

Summarizing, for moderate operating temperatures, a lifetime of more than 5000 h with 100 mV or less voltage decay per cell seems to be achievable using the materials and operating conditions described above for the sub-scale stack.

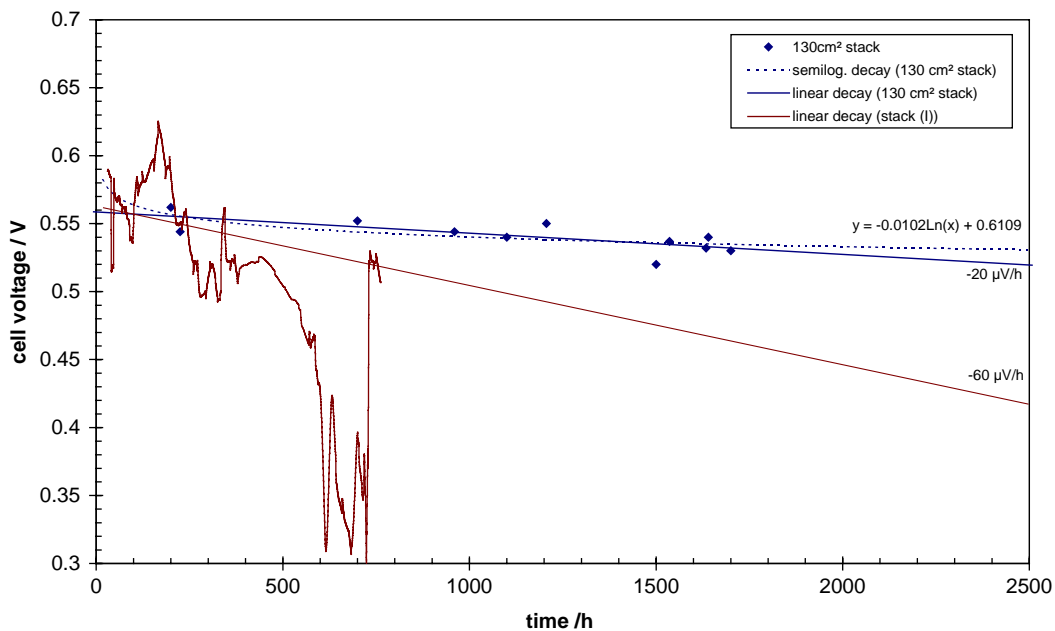

Fig. 11. Voltage–time behavior of a sub-area (130 cm²) and a full size (500 cm², stack I) PEMFC stack.

4. Summary and conclusion

A PEM fuel cell stack design operating close to ambient pressure has been evaluated. The performance observed initially in short stacks could be improved by using optimized gas diffusion layers as well as optimized current collectors.

The performance of the full size stack III exceeded the design specifications. This is verifying the basic design of the stack concept, particularly the sizing of the media manifold channels. Utilization of optimized gas diffusion layers led to improved cell voltage at a given power density.

Long-term experiments revealed stability problems most probably related to localized water management effects, particularly when operated at 70 °C and above. Long term investigations of the optimized GDL in a sub-area stack at reduced operating temperature showed stable operation with a decay rate sufficiently low for portable applications.

Further tests with respect to performance and lifetime of the large area stack III are in progress.

Acknowledgements

The project was carried out in cooperation with SGL Technologies, Sachsenring Fahrzeugtechnik and Zwickau University of Applied Sciences. The project was financially supported by BMWi under contract no. 0327077a.

References

- [1] J. Scholta, B. Rohland, V. Trapp, U. Focken, Investigations on novel low-cost graphite composite bipolar plates, *J. Power Sources* 84 (1999) 231–234.
- [2] M. Arita, Technical issues of fuel cell systems for automotive application, *Fuel Cells* 2 (2002) 10–14.
- [3] J. Garcke, L. Jörissen, J. Scholta, A. Meissner, T. Schroer, J. Snell, Test Case Electric and Hybrid Vehicle Technology, 2001, pp. 68–71.